

SANHUA'S OFFER FOR
REFRIGERATION
APPLICATIONS



SANHUA

*“Strive for perfection,
Pursuit of excellence”*

Sanhua is a leading HVAC&R manufacturer of controls and components with a global footprint and 30 years of experience. Our co-operation with the largest companies in the Automotive,

Appliance and HVAC&R industry makes Sanhua a leading worldwide OEM supplier providing the highest quality components at the most competitive price.

CHILLING
ideas worldwide



SANHUA YOUR ROAD MAP TO THE ECO-DESIGN DIRECTIVE*

KEEPS YOU ONE STEP AHEAD OF THE COMING EFFICIENCY AND ENVIRONMENTAL EUROPEAN CHALLENGES

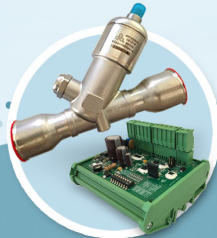

EEV Technology + Electronic Controls

- Improves HVAC_o-R system efficiency up to **20%**
- DPFe-VPF series from 2kW to 1400kW
*75kW and 1400kW available in Quarter 4
- Advanced MSS (Minimum Stable Superheat) control logic



4 Way Reversing Valve

- Improves efficiency by **5%**
- SHF series 1kW to 420 kW
- Widest range in the market with Single Body Design



Inverter Controller for Large System

- Improves system efficiency up to **30%**
- Active Frequency Conversion Technology**
- Wide Range of voltage application

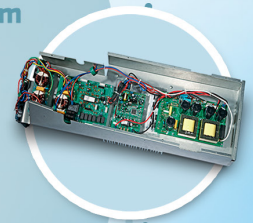

MCHE

- Improves efficiency by **30%**
- Refrigerant Charge Reduction by **30%** Environmental Friendly
- MCHE is lighter in weight, smaller in volume Compact Design



ADERALIES

ADVANCED
Technology & Solutions



CHILLING ideas worldwide

SANHUA INTERNATIONAL
info@sanhuaeurope.com

PRODUCTS FOR REFRIGERATION

Components suitable for installation on refrigeration units Using HFC refrigerants

MICRO CHANNEL HEAT EXCHANGERS

MAIN FEATURES

- Maximum working pressure 4.5Mpa
- Available as both, evaporator and condenser
- High efficiency
- Reducing refrigerant charge

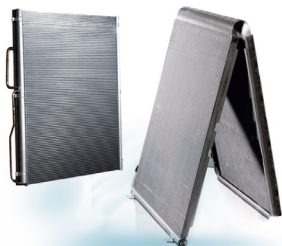

AWECO ROTARY COMPRESSORS

MAIN FEATURES

- High efficient rotary compressors
- Wide portfolio range



ELECTRONIC EXPANSION VALVES (DPF-T SERIES)

MAIN FEATURES

- Step valves for accurate refrigerant flow control
- 500steps (full stroke) - Unipolar with 12V DC Rated Voltage
- Capacity range (3,3 kW to 73,5 kW with R404A)



THERMOSTATIC EXPANSION VALVE (RFKH SERIES)

MAIN FEATURES

- Ready for R448A, R449A, R452A
- Coming soon for R450A, R513A
- Stainless steel capillary and sensing bulb
- Capacity range (1 kW to 24 kW with R410A)
- Thermal bulb utilizes cross charge technology, providing consistent superheat degree over the whole evaporation temperature range



Commercial Refrigeration Application Solutions

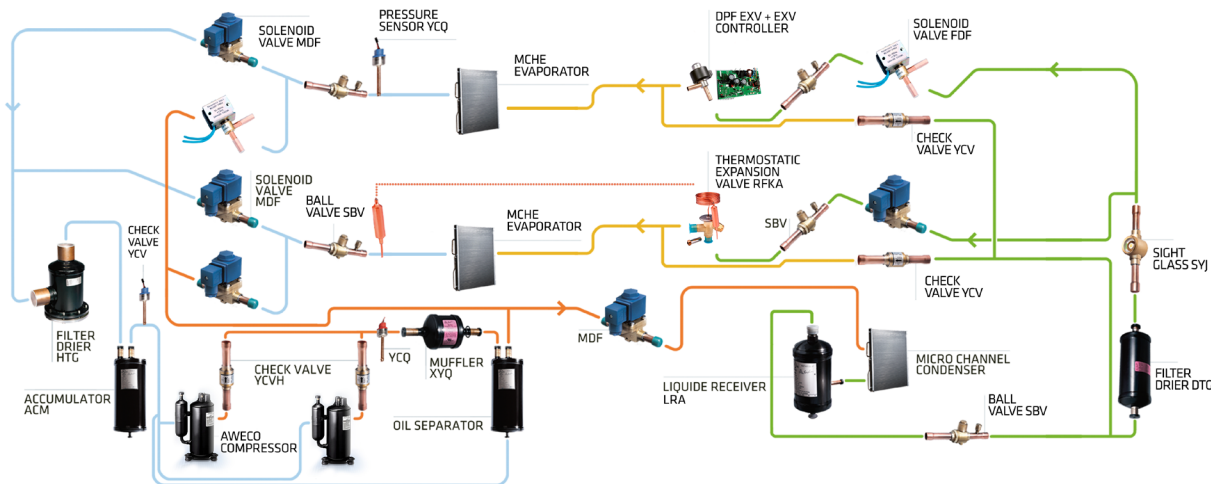

→ Cooling Circle → Discharge Line → Suction Line → Liquid Line → Injection Line

PRODUCTS FOR REFRIGERATION

THERMOSTATIC EXPANSION VALVE (RFGB SERIES)

MAIN FEATURES

- Fixed orifices
- Available with angle shape and fixed super-heating or with straight shape and adjustable super-heating
- Capacity range (1,2 kW to 7,5 kW with R404A)



THERMOSTATIC EXPANSION VALVE (RFGD SERIES)

MAIN FEATURES

- Fixed orifices
- Straight shape and adjustable super-heating
- Capacity range (7,0 kW to 27,4 kW with R404A)

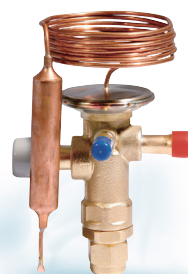

SOLENOID VALVES (MDF, FDF, HDF SERIES)

MAIN FEATURES

- Available range: connections size from 6mm to 54mm (1/4" to 2 1/8")
- New HDF series with piston actuation (Temp. limits: -40°C / +140°C)

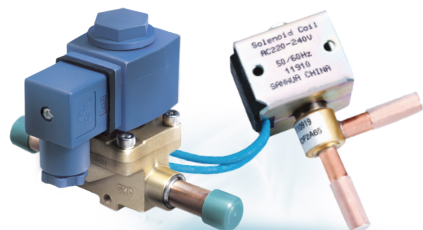

PRESSURE SENSOR (YCQ SERIES)

MAIN FEATURES

- Total accuracy of +/- 2%FS (-30 oC to + 120oC)
- Total accuracy of +/- 0,8%FS (-40 oC to + 40oC)
- High pressure variant up to 5 Mpa and low up to 2 Mpa



ELECTRONIC EXPANSION VALVE (VPF SERIES)

MAIN FEATURES

- Energy saving thanks to very precise capacity control: up to 3800 steps
- Corrosion resistant design, long lifetime, high reliability
- Models with integrated sight glass are available



PRODUCTS FOR REFRIGERATION

Components suitable
for installation on
refrigeration units
Using HFC refrigerants

PISTON CHECK VALVES (YCV SERIES) – STRAIGHT / ANGLE VERSION

MAIN FEATURES

- Piston Type check valves
- Straight type: connection size from 6mm to 22mm (1/4" to 7/8")
- Angle type: connection size from 22mm to 42mm (7/8" to 1 5/8")



BALL VALVES (SBV SERIES)

MAIN FEATURES

- Models with or without access fitting
- Available range: connection size from 6mm to 108mm (1/4" to 4 1/4")



FILTER DRIERS (HTG SERIES)

MAIN FEATURES

- Available with 100% desiccant or 80% desiccant + 20% alumina
- Available with Burn Out core and Mechanical strainer
- Available range: connection size from 16 mm to 54 mm (from 5/8" to 2 5/8"); for 1;2;3;4 replaceable cores



FILTER DRIERS (DTG SERIES)

MAIN FEATURES

- Available with 100% desiccant or 80% desiccant + 20% alumina
- Available range: connection size from 6 mm to 28 mm (1/4" to 1 1/8"). Solder or flare connections



SIGHT GLASSES (SYJ SERIES)

MAIN FEATURES

- High precision color indicator
- Available range: connection size from 6mm to 22mm (1/4" to 7/8")



SANHUA'S GREAT STEP TOWARDS
GREEN TECH LINE
R290, R1270, R600A ...



COMPONENTS DESIGNED
FOR APPLICATIONS
WITH FLAMMABLE FLUIDS
SUCH AS R290/PROPANE

AVAILABLE ALSO FOR
ATEX ZONE



sanhuaclimate.com

GREEN TECH LINE R744 LINE

Regardless sub critical
or transcritical applications
Please let SANHUA take care
of your CO₂

R04 SERIES ELECTRONIC EXPANSION VALVES are specially designed for CO₂ transcritical applications



PS: 14MPa

MOPD: 10MPa

500 STEPS

UNIPOLAR MOTOR

SELF-LUBRICATION

BURST PRESSURE: 42MPa

1.5MM ORIFICE WITH COOLING CAPACITY UP TO 7.5 KW

2.8MM ORIFICE WITH COOLING CAPACITY UP TO 28 KW

NOTES:
● 2.4mm and 3.5mm orifice are also available with PS 6Mpa suitable for sub critical applications.
● For more models please contact sanhua europe.

SUB-CRITICAL BALL VALVES (CBV)

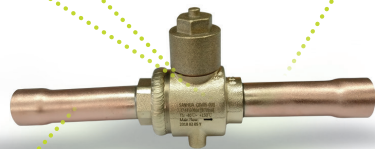

BRASS BODY

COPPER CONNECTION PIPES

DESIGN PRESSURE = 60 BAR

BIDIRECTIONAL FLOW

WIDE TEMPERATURE RANGE SUITABLE FOR REFRIGERATION APPLICATIONS (-40°C TO +150°C)

TRANS-CRITICAL BALL VALVES (CBVT)



SUS304 STAINLESS STEEL CONNECTION PIPES

SUS304 STAINLESS STEEL BODY

BI-METAL CONNECTIONS FOR AN EASY SOLDERING

BIDIRECTIONAL FLOW

DESIGN PRESSURE = 120 BAR

WIDE TEMPERATURE RANGE SUITABLE FOR REFRIGERATION APPLICATIONS (-56°C TO +150°C)

STAINLESS STEEL CHECK VALVES are specially designed for CO₂ transcritical applications



SUS304 STAINLESS STEEL CONNECTION (SOLDERING)

BURST PRESSURE: 42MPa

PS: 14MPa

LASER WELDING

FURNACE WELDING

OPTIMIZED SEALING MATERIAL

Sanhua is providing CO₂ products with various operation pressure

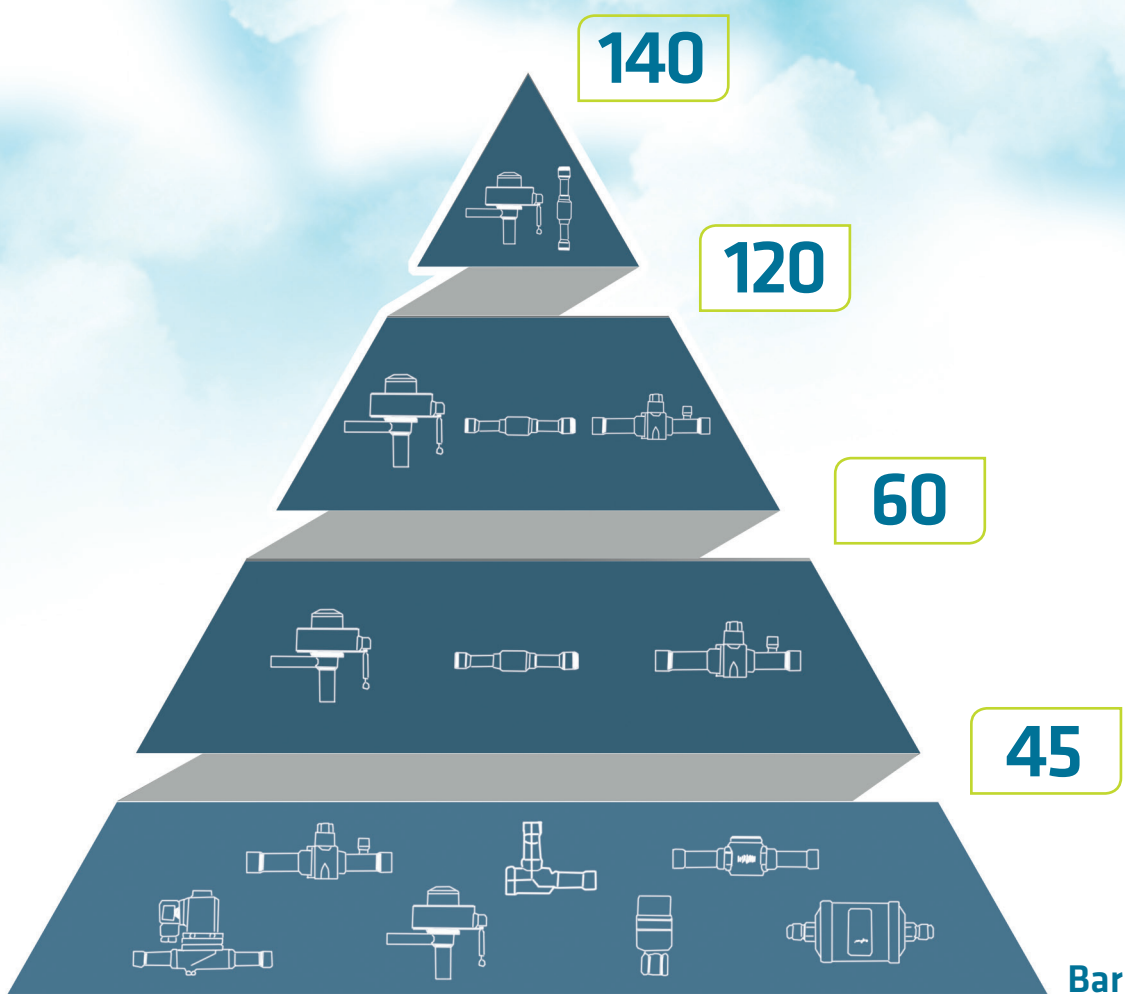

Note: Conditions could change without previous notice due to components updating or typing mistakes. Sanhua declines any responsibility for a wrong product choice based on this table. Please make sure all your requirements are covered in our suggestion.

GREEN TECH LINE

R290, R1270, R600

Components suitable
for applications with flammable
refrigerants
available also for ATEX zone

MICRO CHANNEL HEAT EXCHANGERS

MAIN FEATURES

- Maximum working pressure 4.5Mpa
- Available as both ,evaporator and condenser
- High efficiency
- Reducing refrigerant charge

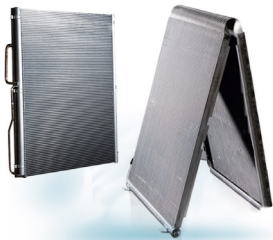

AWECO ROTARY COMPRESSORS

MAIN FEATURES

- High efficient rotary compressors
- Wide portfolio range for R290



ELECTRONIC EXPANSION VALVES (DPF-T SERIES)

MAIN FEATURES

- Standard coils suitable for units with R290 charge below 150g (VDE certificate according to the norm IEC 60335 series)
- Valves for R290 suitable in combination with standard or ATEX coil
- ATEX is coming soon



THERMOSTATIC EXPANSION VALVES (RFGB SERIES)

MAIN FEATURES

- Fixed orifices
- Available with angle shape and fixed super-heating or with straight shape and adjustable super-heating
- Capacity range (1,2 kW to 7,0kW with R290)



SOLENOID VALVES (FDF SERIES)

MAIN FEATURES

- Standard coils suitable for units with R290 (VDE certificate according to the norm DIN EN 60730-1 and IEC 60335 series)
- Available range: connections size from 1/4" to 5/8"



4 WAYS REVERSING VALVES
(SHF SERIES)

MAIN FEATURES

- Standard coils suitable for units with R290 charge below 150g (VDE certificate according to the norm IEC 60336-2-24)
- ATEX coils with different rated voltage available on request
- Available range: nominal capacity from 3.4 to 30.0 kW

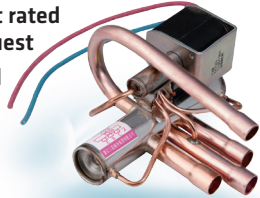

SOLENOID VALVES
(MDF SERIES)

MAIN FEATURES

- Standard coils suitable for units with R290 (VDE certificate according to the norm DIN EN 60730-1 and IEC 60335 series)
- Available range with R290: connections size from 6mm to 22mm (1/4" to 7/8")

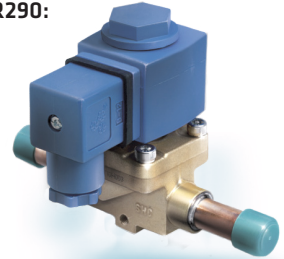

PISTON CHECK VALVES (YCV SERIES)

MAIN FEATURES

- Piston Type check valves
- Available range: connections size from 6mm to 22mm (1/4" to 7/8")



BALL VALVES (SBV SERIES)

MAIN FEATURES

- Models with or without access fitting
- Available range: connections size from 6mm to 22mm (1/4" to 7/8")



SIGHT GLASSES (SYJ SERIES)

MAIN FEATURES

- High precision color indicator
- Available range: connections size from 6mm to 22mm (1/4" to 7/8")



FILTER DRIERS (DTG, STG SERIES)

MAIN FEATURES

- Available with 100% desiccant or 80% desiccant + 20% alumina
- Available range: connections size from 6mm to 22mm (1/4" to 7/8")





sanhuaclimate.com

SANHUA INTERNATIONAL
info@sanhuaeurope.com



SANHUA
CHILLING ideas worldwide

